

# ARTERIOS

## DUSTIN ACCENT TABLE

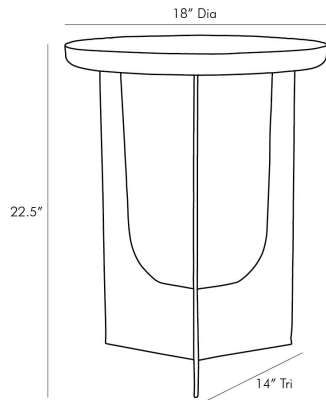

4807

H: 22.5 IN, Dia: 18.00 IN

Natural Iron

Contract Recommendations: Adding a lacquer coating provides additional protection.

Inspired by the rigid geometric style that is a prominent element in Brutalist architecture this seemingly simple accent table possesses details that make it complex. A mango wood top has been chiseled by hand showcasing carved details that have been softened by a black wax finish. It is perfectly poised on a hammered iron base which lends a textural element to the intense angles that define its form. It's scaled to fit in a

### APPEARANCE

Material	Iron, Mango Wood
Finish	Natural Iron, Soft Black Waxed
Finish Will Vary	true
Top Coat/Sealant	false

### DIMENSIONS

Foot Print	W: 14 IN, D: 14 IN
Table Top	H: 2 IN, Dia: 18.00 IN

### SHIPPING

Product Weight	24 LBS
Gross Weight 1	33 LBS
Shipping Box 1	H: 21 IN, L: 21 IN, W: 26 IN

### CONTRACT

Contract Suitable	Adding a lacquer coating provides additional protection
-------------------	---