

# ARTERIOS

## EQUINOX LAMP

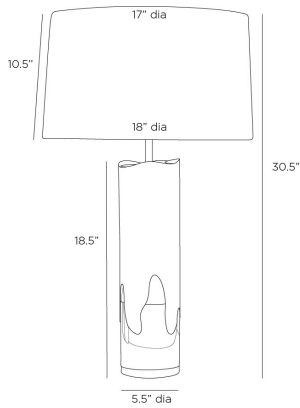

PTC46-SH049  
 H: 30.5 IN, Dia: 18.00 IN  
 Clear, Crystal  
 Contract Suitable As Is

The alchemy of melted metal in one sleek column lamp. Crystal is adorned in flowing antique brass, with an undulating edge that draws the eye. Matching antique brass hardware and off-white microfiber drum shade.

### APPEARANCE

Material Cotton, Crystal, Microfiber, Steel  
 Finish Antique Brass, Off-White  
 Top Coat/Sealant false  
 Finial Description Antique brass sphere  
 Finial Dimension 1" Dia

### DIMENSIONS

Shade Top: 17.00 IN, Dia: 18.00 IN, Side: 10.5 IN  
 Body H: 18.5 IN, Dia: 5.50 IN  
 Neck H: 2 IN, Dia: 0.50 IN  
 Foot Print Dia: 5.50 IN  
 Harp 9 IN

### WIRING

Rating Indoor Only  
 Tilt Test 10 Degrees - AU  
 Cord 9 FT, Exits Neck, SPT-2, Taupe Fabric  
 Socket 1, Antique Brass, Type A - E26  
 Switch 3-Way Rotary, At Socket  
 Maximum Watt 150  
 Voltage 110-120 V

### COMPLIANCY

RoHS true

### SHIPPING

Product Weight 25.4 LBS  
 Gross Weight 1 30 LBS  
 Gross Weight 2 5 LBS  
 Shipping Box 1 H: 28 IN, L: 10 IN, W: 10 IN  
 Shipping Box 2 H: 35 IN, L: 19.3 IN, W: 19.3 IN

### ADDITIONAL INFO

Shade Shape Round  
 Shade Trim Rolled Edges  
 Shade Type Hardback

### CONTRACT

Contract Suitable true