

ARTERIOS

ANSEL BAR STOOL

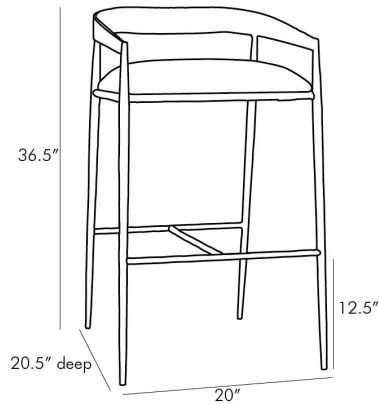

4747

H: 36.5 IN, W: 20 IN, D: 20.5 IN

Sterling Linen, Hammered Iron

Contract Recommendations: Adding a lacquer coating provides additional protection.

Sharp angles and an unrefined curvature define the bold aesthetic of this stool. Natural iron has been hammered by hand to create the rich impressions seen along the shallow back while the hand-forged legs yield more delicate details. The tight seat is covered in sterling linen elegantly elevating its textured façade. Also available as a counter stool (4746).

APPEARANCE

Material	Iron, Linen
Material Type	Forged
Finish	Natural Iron, Sterling
Top Coat/Sealant	false

DIMENSIONS

Yardage To Reupholster	0.66
Seat	W: 18 IN, D: 9.5 IN
Seat Height	30 IN
Seat Cushion Thickness	3 IN
Seat	W: 18 IN, D: 9.5 IN

SHIPPING

Shipping Requirements	TruckShip
Product Weight	46.5 LBS
Gross Weight 1	52.35 LBS
Shipping Box 1	H: 33 IN, L: 26 IN, W: 23 IN

ADDITIONAL INFO

Fabric Composition	100% Polyester
Fabric Double Rub Count	15,000
Fabric Compliancy	NFPA-260, TB117-2013

CONTRACT

Contract Suitable	Adding a lacquer coating provides additional protection
Contract Textile Suitability	Low Traffic/Private Spaces
Swatch Number	L15SW, L158X8