

ARTERIO RS

TOBIN END TABLE

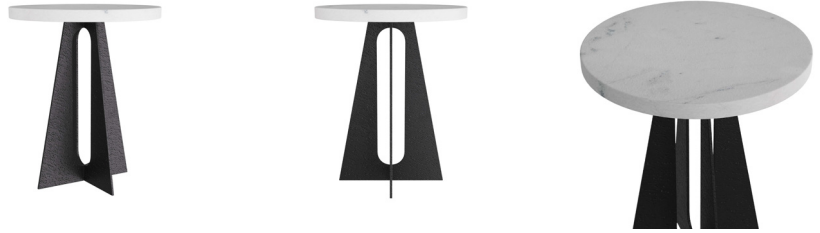
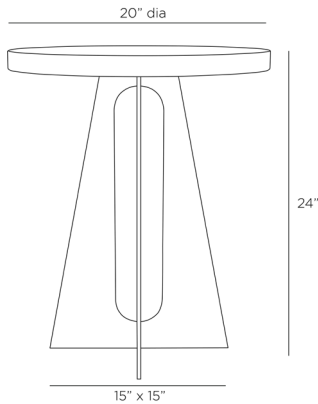

FEI02

H: 24 IN, Dia: 20.00 IN

Blackened

Contract Recommendations: Adding a lacquer coating provides additional protection.

A commanding presence in any living space, our modern and masterful Tobin end table is conceived in contrasting materials, with a design bearing ample visual weight. With brutalist design origins, the table is created with a textured, white marble top that sits atop open, intersecting planes of heavily hammered, blackened iron pedestals. Finish will vary.

APPEARANCE

Material	Iron, Marble
Finish	Blackened Iron
Finish Will Vary	true
Top Coat/Sealant	false

DIMENSIONS

Foot Print	W: 15 IN, D: 15 IN
Table Top	H: 1.5 IN, Dia: 20.00 IN

SHIPPING

Shipping Requirements	TruckShip
Product Weight	71 LBS
Gross Weight 1	80.52 LBS
Shipping Box 1	H: 24 IN, L: 24 IN, W: 28 IN

ADDITIONAL INFO

Leg Or Foot Application	None
-------------------------	------

CONTRACT

Contract Suitable	Natural stone requires periodic sealing, Adding a lacquer coating provides additional protection
-------------------	--