

# ARTERIOS

## TRAINOR BAR CART

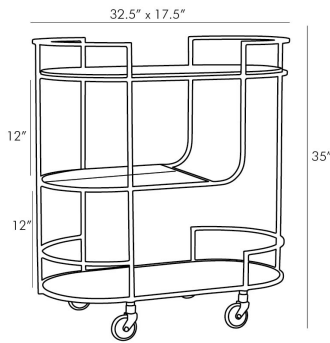

6857

H: 35 IN, W: 32.5 IN, D: 17.5 IN

Antique Brass

Contract Recommendations: Natural stone requires periodic sealing

Serve your guests without forfeiting function or style. Crafted with an iron frame in an antique brass finish, each of the three tiers of this capsule-shaped bar cart features a different element. The top tier is inset with solid white marble, the second tier is inset with clear glass and the third tier is inset with mirrored glass. The use of mixed materials delivers a luxe visual appeal. finish will vary.

### APPEARANCE

Material	Glass, Iron, Marble
Finish	Clear, White
Finish Will Vary	true
Top Coat/Sealant	false

### DIMENSIONS

Shelf	W: 18.5 IN
-------	------------

### SHIPPING

Shipping Requirements	TruckShip
Product Weight	76 LBS
Gross Weight 1	116 LBS
Shipping Box 1	H: 43 IN, L: 41 IN, W: 28 IN

### CONTRACT

Contract Suitable	false
-------------------	-------