

ARTERIOS

NAKOA BAR CART

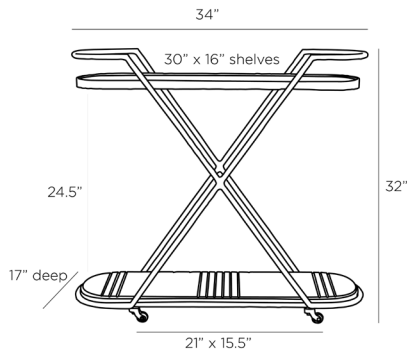

4650

H: 32 IN, W: 34 IN, D: 17 IN

Blackened Iron

Contract Recommendations: Adding a lacquer coating provides additional pro-

The Nakoa celebrates Art Deco design through rich texture and elegant form. A blackened iron foundation presents a minimalist profile with x-shaped legs that rest on an attached black marble base that doubles as a shelf. The marble features a chiseled deco pattern for a look that emphasizes the machine-age and sleek geometric aesthetic, further playing up its architectural inspiration. A clear glass top makes this bar

APPEARANCE

Material	Glass, Iron, Marble
Material Type	Etched
Finish	Black, Blackened Iron, Clear
Finish Will Vary	true
Top Coat/Sealant	true

DIMENSIONS

Foot Print	16 IN
Shelf	W: 21 IN, D: 15.5 IN
	W: 30 IN, D: 16 IN

SHIPPING

Shipping Requirements	TruckShip
Product Weight	84.88 LBS
Gross Weight 1	101.41 LBS
Shipping Box 1	H: 36.5 IN, L: 35 IN, W: 19 IN

ADDITIONAL INFO

Leg Or Foot Application	Caster Wheel
-------------------------	--------------

CONTRACT

Contract Suitable	false
-------------------	-------