

# ARTERIOS

## PRINCETON MIRROR

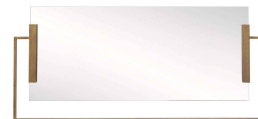
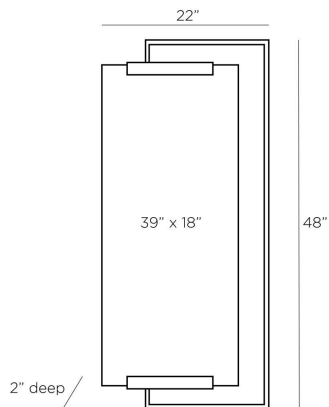

WMI03

H: 48 IN, W: 22 IN, D: 2 IN,

Antique Brass

Contract Suitable As Is

Sleek and modern, the Princeton is created with an offset, forged iron frame and a mirror braced by etched clamps. The geometric mirror is striking alone or as a pair flanking a bathroom vanity. The vertical mirror is fitted with a security cleat for hanging. Finishes will vary.

### APPEARANCE

Material	Iron, Mirror
Finish	Antique Brass, Plain
Top Coat/Sealant	No

### DIMENSIONS

Actual Mirror	H: 39 IN, W: 18 IN
---------------	--------------------

### SHIPPING

Shipping Requirements	TruckShip
Product Weight	33 lbs
Gross Weight 1	44.1 lbs
Shipping Box 1	H: 55 IN, L: 8 IN, W: 33 IN

### ADDITIONAL INFO

Features	T-Screw Hardware Included
Hanger Position	All Four Directions
Hanger Type	Security Cleat
Hanger Size	12"

### CONTRACT

Contract Suitable	Yes
-------------------	-----